

M-216 OPERATOR'S MANUAL

M-216
Wireless
Microphone
Transmitter



COMTEK®

TABLE OF CONTENTS

| | |
|---------------------------------------|-------|
| Introduction | 1 |
| Setup | 2 |
| Controls | 3 |
| Battery Removal / Replacement | 4 |
| Battery Charging | 5 |
| Auxiliary Audio Input Operation | 6-7 |
| Snap-On Belt Clip | 7 |
| Frequency Selection | 8 |
| Frequency Information | 9-10 |
| Optional Accessories | 11 |
| Options | 12 |
| HH-185 | 13 |
| Trouble Shooting | 14-15 |
| Specifications | 16 |
| Warranty and Service | 17 |

INTRODUCTION

M-216 ***Wireless*** ***Microphone*** ***Transmitter***

The M-216 wireless microphone transmitter offers the ultimate performance and versatility for assistive listening, language interpretation, tour guide presentations, personal communication, and for other personal remote transmission situations.

The M-216 incorporates the latest digital and analog technologies to produce low residual noise, wide dynamic range, and extended frequency response rendering the most natural sound possible from a wireless microphone.

The transmitter's microcontroller automatically sets the modulation deviation, companding or non-companding audio processing, and the EQ when corresponding channels are selected. Because of this comprehensive feature, this versatile transmitter can transmit on 19 high fidelity channels and 38 standard channels ensuring compatibility with receivers conforming to regulations regarding Low Power Radio Service (LPRS) transmissions in the 216-217 MHz band under Part 95 of the FCC regulations.



M-216 SETUP

Setup

a. Check to ensure that the M-216 transmitter's radio frequency channel is the same as the associated COMTEK receiver's channel. (Channels are indicated by the rotary channel selector switches on the back of the transmitter. See page 3.)

b. Open the battery door cover on the transmitter (see page 4) and insert a new nine volt alkaline battery (Eveready E522 or equivalent). This type of battery will offer up to 30 hours of operation. *Replace the battery before every use if the demand for fail-safe operation outweighs battery cost. The use of carbon batteries is not recommended.*

NOTE: If a rechargeable battery is to be used, ensure that it has been allowed to charge at least 14 hours to bring it to full charge (see page 5 for battery charger instructions).

c. Connect the microphone to the transmitter by inserting the microphone plug into the receptacle on the top of the transmitter. The transmitter is operating when the transmitter power switch is turned on and the battery status on indicator illuminates.

NOTE: The 36-inch microphone cord also functions as part of the transmitter's antenna system. For optimum performance, this cord should be fully extended. Coiling or bunching the microphone cord may reduce the range of the transmitter. The transmitter should be carried by the snap-on belt clip (included) or in a pocket or belt-clip pouch.

d. In a situation where an extremely loud voice or a very soft voice is used, it is necessary to adjust the audio input gain control while observing the audio "voice" level modulation indicator. A full bright LED indicates full audio compression at 100% modulation. For best performance, the audio input gain should be adjusted for some low level LED luminescence during normal audio levels with occasional full bright peaks indicating 100% modulation.

M-216 CONTROLS

❶ OPTIONAL COMPAND AUTO / OFF SWITCH: This switch overrides the automatic selection of the companded channels for non-companded operation. (This switch should remain in the “Auto” position.)

❷ CHANNEL SWITCHES: These rotary switches are set to the same channel as the receiver. Actual frequency of operation must agree with the receiver. (See page 10 for frequency selection chart.)

❸ BATTERY COMPARTMENT: The battery compartment features a hinged battery cover and an alignment system that ensures proper battery polarity. Battery installation and removal is facilitated by simply manipulating the bottom of the battery.

❹ AUXILIARY AUDIO INPUT JACK: Allows transmitter to use line level, earphone level, or fixed AUX as an audio source.

❺ AUDIO “VOICE” MODULATION INDICATOR: This indicator is used in making adjustment with the Audio Input Gain Control.

❻ MIC / ANTENNA JACK: This jack accepts an electret type microphone having a 36” long cord with a micro-mini 2.5 mm mono plug. This jack is also used for the R.F. output for the screw-in whip antenna when only the auxiliary audio input is used.

❼ POWER / BATTERY STATUS INDICATOR: This LED indicator will illuminate continuously when the unit is on indicating normal operation. When the battery voltage drops below 6 volts, the LED will flash *rapidly* indicating that a new battery is needed.

❽ OPTIONAL MIC MUTE SWITCH: This switch turns off the microphone without turning off the transmitter carrier.

❾ AUDIO INPUT GAIN CONTROL: This is a microphone and AUX level input gain control. This control is used with the “Voice” modulation indicator.

❿ ON / OFF SWITCH: This switch turns the transmitter on and off.

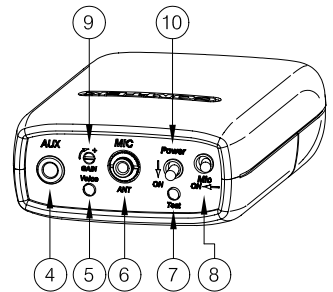
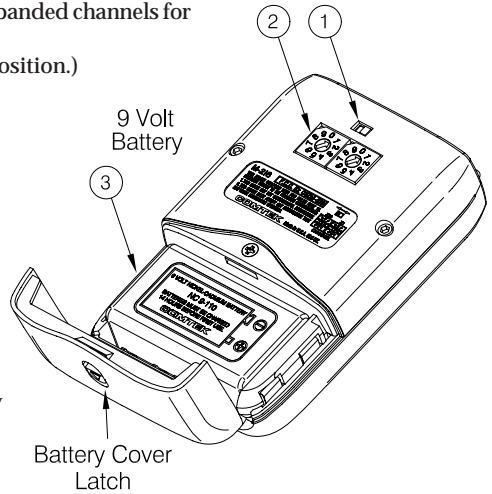

M-216 BATTERY REMOVAL / REPLACEMENT

Low Battery Indicator

The LED on the top of the transmitter indicates the status of the battery as well as indicating that the unit is turned on. When turned on, the LED illuminates. If the battery is low the green LED will blink rapidly warning that the battery will soon be dead. Replace a low battery immediately.

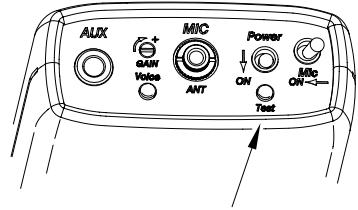

Battery indicator LED

Battery Removal / Replacement

Pull back battery door latch and allow battery cover door to spring open. To remove battery, simply manipulate the bottom of battery out of the compartment and remove.

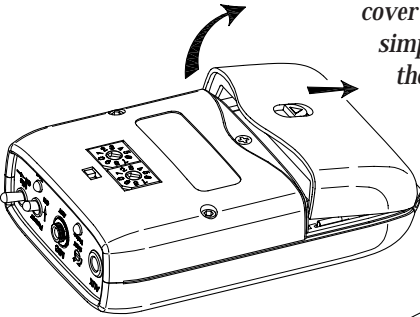

To insert battery, face battery with negative terminal in line with large hole in battery compartment, press battery into compartment and close battery door until it snaps shut. Note: It is not possible to put battery in backwards.

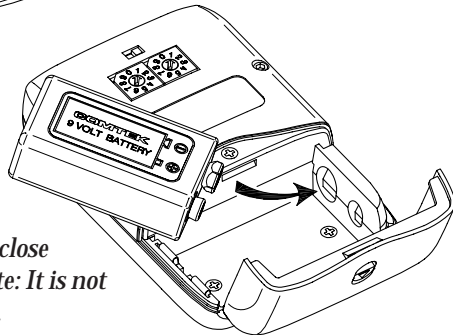

M-216 BATTERY CHARGING

Battery Charging

1. Make sure that a seven cell 9 volt Ni-MH rechargeable battery is used with a minimum of 200 mAh capacity. **(Alkaline batteries must not be charged.)**
2. Make sure the M-216 is turned **OFF**.
3. Note that the red charging indicator on the charger is **ON** when the M-216 is plugged into the charger through the auxiliary audio input jack.
4. When using the **NBC 9-2C** charger allow the battery to charge for 14 hours for a full charge. Unit must then be unplugged. When using the **NBC 9-3-1** digital fast charger the charger will automatically end the charge cycle and the red LED will change to green. With the **NBC 9-3-1** charger the unit may be left in the charger until the unit is used.
5. Periodically open the battery compartment on stored COMTEK units to check for battery leakage. If a battery is leaking, it must be discarded, and the battery compartment must be cleaned or returned to COMTEK's service department for repairs.

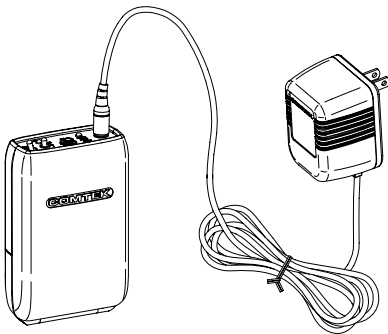

NBC 9-2C
14-hour charger

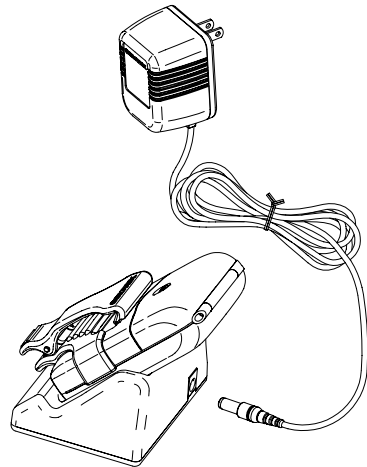

NBC 9-3-1
digital fast charger

M-216 AUXILIARY AUDIO INPUT OPERATION

Auxiliary Audio Input Operation

The M-216 transmitter may transmit from a variety of audio sources such as digital media players, or any audio device having an auxiliary or earphone level audio signal.

The auxiliary input cable supplied with the M-216 transmitter (CB-36 ST) will operate with any device having a mini 3.5 mm jack, stereo or mono, and with line level or earphone level output.

To accommodate a variety of specialty applications, auxiliary input cables with RCA phono plug, 1/4" audio phone plug, and XLR connectors are available from COMTEK.

Setup

a. Plug the micro-mini screw-lock whip antenna into the top center jack (mic/ant.) of the M-216 transmitter. The whip antenna should be in a vertical position away from any metallic objects to ensure maximum range performance.

b. Connect the proper auxiliary input cable to the audio source. Connect the right-angle mini plug end of the auxiliary input cable into the "AUX" input jack of the M-216 transmitter.

Note: Check to ensure that the audio source is a line level, earphone level, or fixed AUX level output.

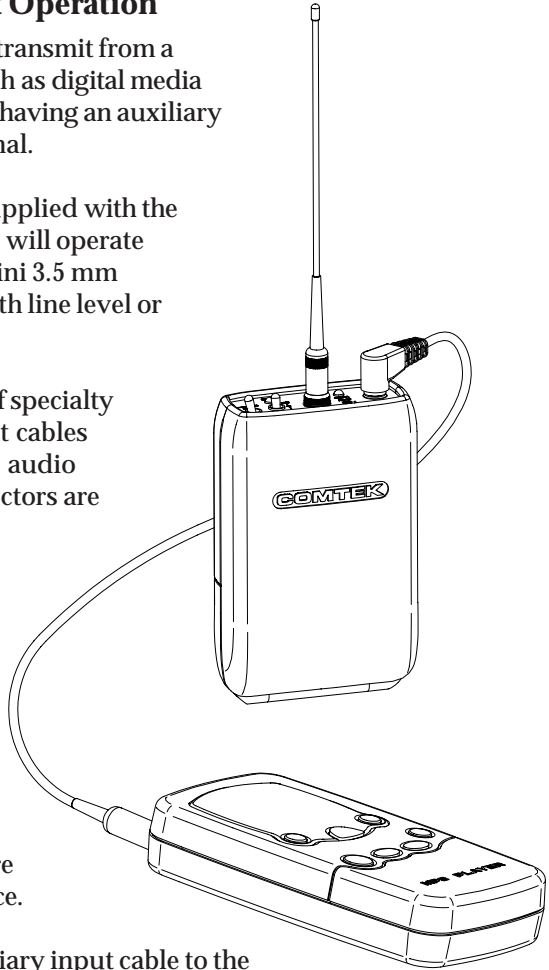

(continued)

M-216 SNAP-ON BELT CLIP

c. Turn on the transmitter with program from the audio source being fed to the transmitter. Observe the audio “voice” level modulation indicator. A full bright LED indicates full audio compression at 100% modulation. For best performance, the audio input gain should be adjusted for some low level LED luminescence during normal audio levels with occasional full bright peaks indicating 100% modulation.

d. When using the auxiliary audio input with the microphone plugged into the transmitter, priority should be given to the microphone gain adjustment. The mixing balance between the auxiliary audio and the microphone should be made with the volume control of the auxiliary audio source.

Note: The optional microphone mute switch only affects the microphone. It does not affect the auxiliary audio input.

M-216 SNAP-ON BELT CLIP (Included)

Belt clip installation

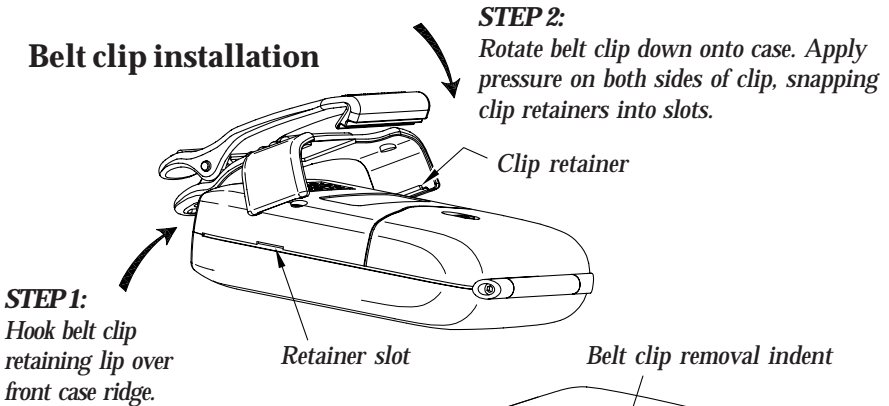

Belt clip removal

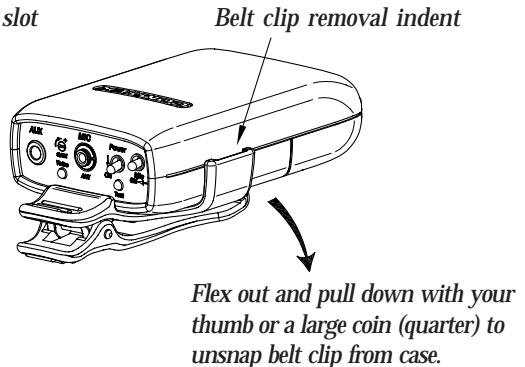

M-216 FREQUENCY SELECTION

Frequency Selection (216-217 MHz)

The M-216 transmitter can operate on one of 57 available frequencies between 216 MHz and 217 MHz. COMTEK's channel designations indicate both non-companded standard channels and high-fidelity, companded channels. Channels 1-40 are non-companded channels offering compatibility with other manufacturers' receivers. Channels 41-60 are high-fidelity, companded channels for use with COMTEK receivers. COMTEK transmitters automatically transmit the proper mode when set to channels 1-40 for non-companded or 41-60 for companded channels.

Note: The optional compand switch should remain in the "Auto" position.

After you have determined the channel on which you are going to operate, position the two rotary switches to indicate the channel. The left rotary switch is for *tens* and the right rotary switch is for *ones*, e.g. to select channel 41 (216.0250 MHz), position the left rotary switch to point to 4 (X10), and position the right rotary switch to point to 1 (X1).

Refer to frequency charts on pages 9 and 10 for selectable frequencies.

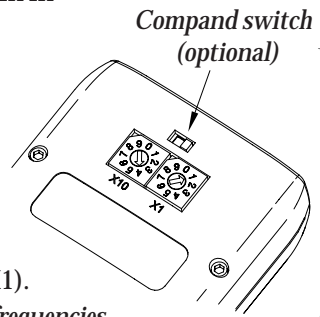

Multiple Channel Operation

When multiple transmitters are broadcasting in the same immediate area (within 100 feet), the RF signals will "mix" together generating additional signals. If these product frequencies are too close to a frequency which you are using, you will experience intermodulation interference. This condition is common to all radio receivers to some extent.

Simultaneous operation of more than three channels requires frequency coordination to avoid intermodulation interference, which could result in poor or unusable performance.

To avoid this type of interference, you should select frequencies from one of the standard groups (see frequency group charts on page 10), or use COMTEK's frequency selection software (www.comtek.com/support.html) to determine appropriate frequencies or contact COMTEK to obtain a free copy.

M-216 FREQUENCY INFORMATION

Non-Companded Channels
 For use with COMTEK and other manufacturers
 (Educational Standard)

| CHANNEL (SWITCH POSITION) | FREQUENCY |
|------------------------------|--------------|
| 01 | 216.0125 MHz |
| 02 | 216.0375 MHz |
| 03 | 216.0625 MHz |
| 04 | 216.0875 MHz |
| 05 | 216.1125 MHz |
| 06 | 216.1375 MHz |
| 07 | 216.1625 MHz |
| 08 | 216.1875 MHz |
| 09 | 216.2125 MHz |
| 10 | 216.2375 MHz |
| 11 | 216.2625 MHz |
| 12 | 216.2875 MHz |
| 13 | 216.3125 MHz |
| 14 | 216.3375 MHz |
| 15 | 216.3625 MHz |
| 16 | 216.3875 MHz |
| 17 | 216.4125 MHz |
| 18 | 216.4375 MHz |
| 21 | 216.5125 MHz |
| 22 | 216.5375 MHz |
| 23 | 216.5625 MHz |
| 24 | 216.5875 MHz |
| 25 | 216.6125 MHz |
| 26 | 216.6375 MHz |
| 27 | 216.6625 MHz |
| 28 | 216.6875 MHz |
| 29 | 216.7125 MHz |
| 30 | 216.7375 MHz |
| 31 | 216.7625 MHz |
| 32 | 216.7875 MHz |
| 33 | 216.8125 MHz |
| 34 | 216.8375 MHz |
| 35 | 216.8625 MHz |
| 36 | 216.8875 MHz |
| 37 | 216.9125 MHz |
| 38 | 216.9375 MHz |
| 39 | 216.9625 MHz |
| 40 | 216.9875 MHz |

High-Fidelity Companded Channels
 For use with COMTEK equipment only
 (Companded)

| CHANNEL (SWITCH POSITION) | FREQUENCY |
|------------------------------|--------------|
| 41 | 216.0250 MHz |
| 42 | 216.0750 MHz |
| 43 | 216.1250 MHz |
| 44 | 216.1750 MHz |
| 45 | 216.2250 MHz |
| 46 | 216.2750 MHz |
| 47 | 216.3250 MHz |
| 48 | 216.3750 MHz |
| 49 | 216.4250 MHz |
| 51 | 216.5250 MHz |
| 52 | 216.5750 MHz |
| 53 | 216.6250 MHz |
| 54 | 216.6750 MHz |
| 55 | 216.7250 MHz |
| 56 | 216.7750 MHz |
| 57 | 216.8250 MHz |
| 58 | 216.8750 MHz |
| 59 | 216.9250 MHz |
| 60 | 216.9750 MHz |
| 61 | 216.0250 MHz |
| 62 | 216.0750 MHz |
| 63 | 216.1250 MHz |
| 64 | 216.1750 MHz |
| 65 | 216.2250 MHz |
| 66 | 216.2750 MHz |
| 67 | 216.3250 MHz |
| 68 | 216.3750 MHz |
| 69 | 216.4250 MHz |
| 71 | 216.5250 MHz |
| 72 | 216.5750 MHz |
| 73 | 216.6250 MHz |
| 74 | 216.6750 MHz |
| 75 | 216.7250 MHz |
| 76 | 216.7750 MHz |
| 77 | 216.8250 MHz |
| 78 | 216.8750 MHz |
| 79 | 216.9250 MHz |
| 70 | 216.9750 MHz |

M-216
216 MHz
NON-COMPANDED
FREQUENCY GROUPS
 Compatible with COMTEK
 and other manufacturers

GROUP A

| CHANNEL | FREQUENCY |
|---------|--------------|
| 1 | 216.0125 MHz |
| 9 | 216.2125 MHz |
| 15 | 216.3625 MHz |
| 24 | 216.5875 MHz |
| 31 | 216.7625 MHz |
| 36 | 216.8875 MHz |

GROUP B

| CHANNEL | FREQUENCY |
|---------|--------------|
| 4 | 216.0875 MHz |
| 10 | 216.2375 MHz |
| 14 | 216.3375 MHz |
| 32 | 216.7875 MHz |
| 35 | 216.8875 MHz |
| 40 | 216.9875 MHz |

GROUP C

| CHANNEL | FREQUENCY |
|---------|--------------|
| 3 | 216.0624 MHz |
| 5 | 216.1125 MHz |
| 12 | 216.2875 MHz |
| 22 | 216.5375 MHz |
| 38 | 216.9375 MHz |

GROUP D

| CHANNEL | FREQUENCY |
|---------|--------------|
| 17 | 216.4125 MHz |
| 23 | 216.5625 MHz |
| 30 | 216.7375 MHz |
| 34 | 216.8375 MHz |
| 39 | 216.9625 MHz |

M-216
216 MHz
COMPANDED
FREQUENCY GROUPS
 For COMTEK
 equipment only

GROUP 1

| CHANNEL | FREQUENCY |
|---------|--------------|
| 41 | 216.0250 MHz |
| 44 | 216.1750 MHz |
| 51 | 216.5250 MHz |
| 55 | 216.7250 MHz |
| 60 | 216.9750 MHz |

GROUP 2

| CHANNEL | FREQUENCY |
|---------|--------------|
| 42 | 216.0750 MHz |
| 49 | 216.4250 MHz |
| 53 | 216.6250 MHz |
| 58 | 216.8750 MHz |

GROUP 3

| CHANNEL | FREQUENCY |
|---------|--------------|
| 43 | 216.1250 MHz |
| 46 | 216.2750 MHz |
| 51 | 216.5250 MHz |
| 57 | 216.8250 MHz |

GROUP 4

| CHANNEL | FREQUENCY |
|---------|--------------|
| 44 | 216.1750 MHz |
| 47 | 216.3250 MHz |
| 54 | 216.6750 MHz |
| 59 | 216.9250 MHz |

M-216 OPTIONAL ACCESSORIES

Optional Accessories

1. NBC 9-2C Battery charger
2. NH 9-200 Rechargeable batteries
3. P-1 Universal pouch
4. BC-216 Snap-on belt clip (supplied with M-216)
5. LW-216 Whip antenna (supplied with M-216)
6. HM-100C Headworn unidirectional electret microphone
7. HH-185 Handheld microphone boom adaptor
8. TM-10 Conference table microphone adaptor
9. SM-185RT Unidirectional electret condenser microphone

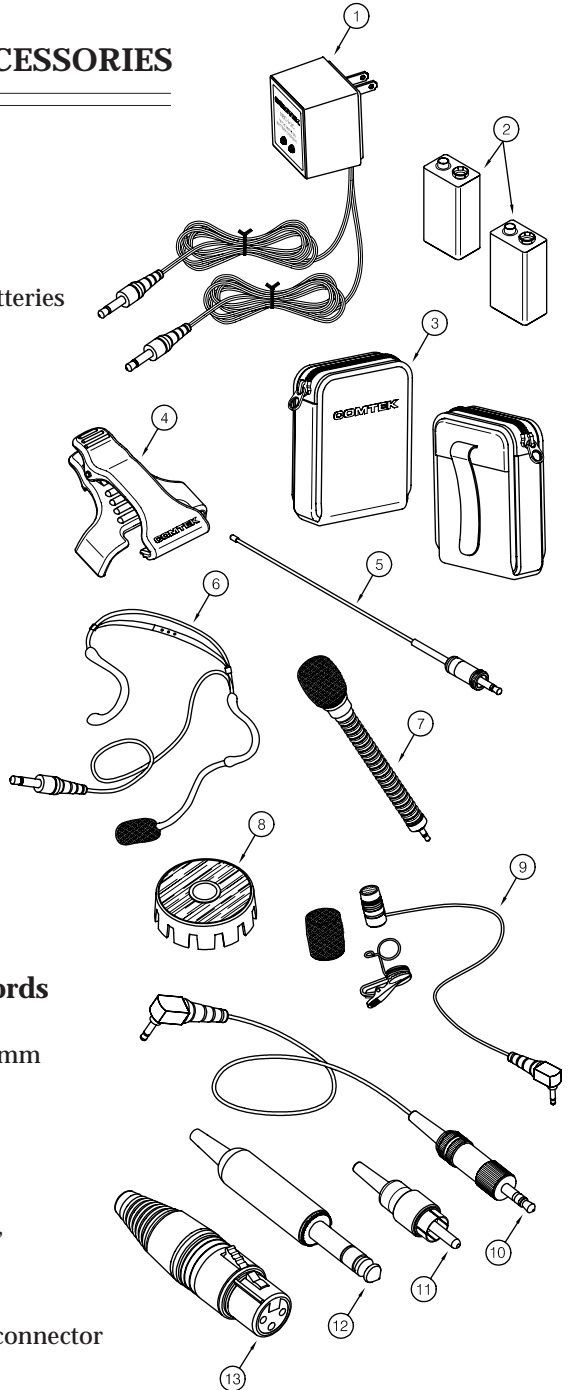

Auxiliary Audio Input Cords

10. CB-36 ST Stereo mini 3.5 mm (supplied with M-216)
11. CB-36 RCA Phono plug (optional)
12. CB-36 ST 1/4 Stereo 1/4" (optional)
13. CB-36 XLR XLR-F 3 pin connector (optional)

M-216 OPTIONS

Option P-7

The optional P-7 M-216 transmitter may be body worn on a belt with the snap-on belt clip or may be inserted in the optional MBS-216 mounting bracket stand for easy system setup. The MBS-216 is ideal for on location program monitoring for large area coverage.

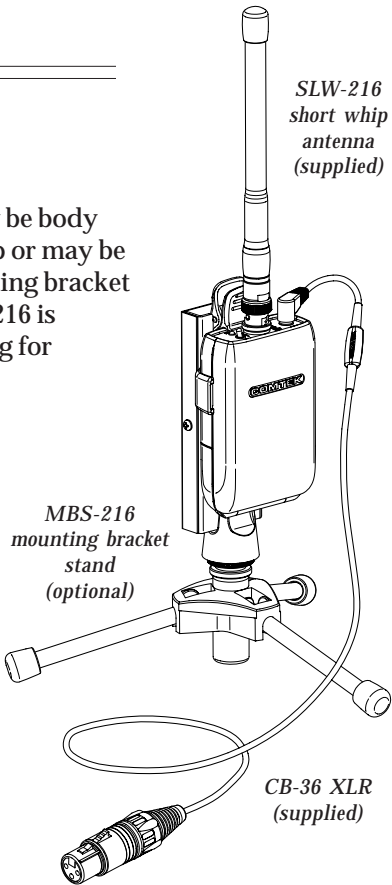
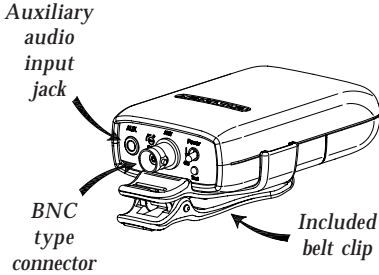

Option 1

The optional microphone mute switch allows the speaker's voice from the M-216 transmitter to be muted while the aux input audio remains on. When the microphone switch is turned back on the aux audio level is automatically lowered 6 dB to prioritize the speaker's voice.

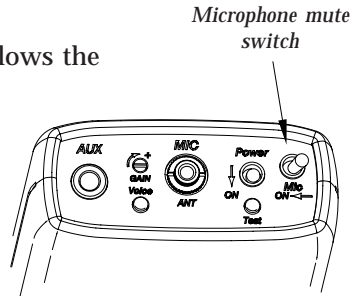

M-216 / HH-185

Optional HH-185 Handheld Boom Microphone

For added versatility, the HH-185 cardioid boom microphone allows the standard M-216 transmitter to be used as a handheld “pass-around” wireless microphone. The HH-185 microphone gain is adjusted with the gain control on the M-216 transmitter. This allows the user to optimize the sensitivity of the microphone when it is used in a high background noise environment. The HH-185 boom incorporates a unique integral antenna design so no external antenna is required while still maintaining full transmission.

The HH-185 boom microphone can also be used with the PR-216 personal receiver equipped with the Option 2P for auditory assistance applications. When plugged into the PR-216 personal receiver, the gain of the boom microphone can be independently adjusted to a gain level sufficient to selectively pick up a single voice in a group. This isolates a particular voice while receiving a voice signal from the M-216 wireless microphone transmitter.

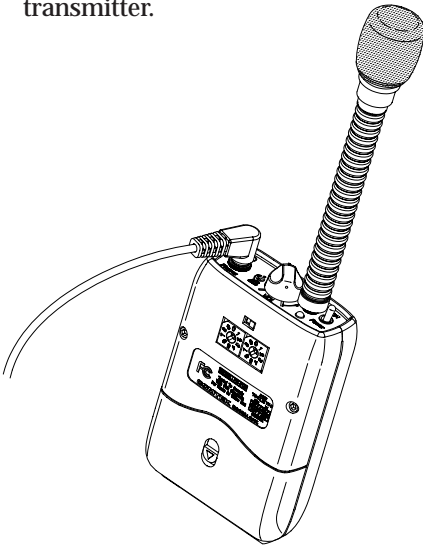

PR-216
Personal Receiver

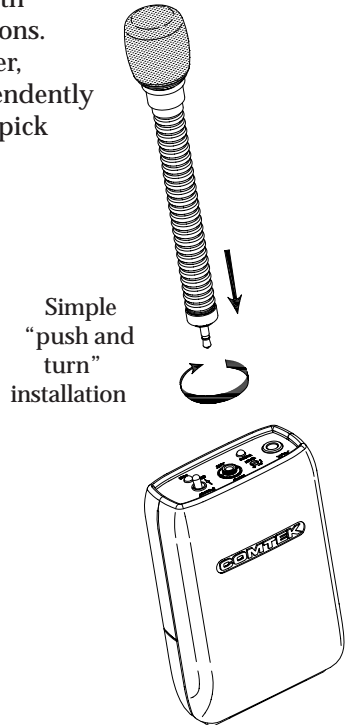

Simple
“push and
turn”
installation

M-216
Transmitter

M-216 TROUBLE SHOOTING

Batteries and Battery Charging

If...

Test indicator lamp doesn't illuminate when units are turned on...

Then...

- If rechargeable batteries are used, ensure that they have been allowed to charge at least 14 hours to a full charge. Verify that the charging indicator lamps are illuminated when the charging plugs are plugged into the units. ***The units' power switches must be in the "off" position for charging.***
- If the test indicator lamp still does not illuminate after a full charge, verify that the system is operational by using a new alkaline battery. If the system is operational with alkaline batteries, the rechargeable batteries or charger may need to be replaced.
- The M-216 transmitter must be returned to COMTEK for service if the test indicator lamp does not illuminate when new alkaline batteries are used.

Transmitter Audio Problem

If...

There is no visual indication on the "voice" modulation level indicator when speaking into the microphone of the M-216 transmitter...

Then...

- Turn up the microphone gain setting clockwise until the voice modulation indicator illuminates with speech level.
- Make sure the optional muting switch is in the "mic on" position.
- Check the CM-183RT microphone for a broken or frayed microphone cord that may cause intermittent operation.
- Test the modulation indicator with the auxiliary audio input using a line level signal and the CB-36ST auxiliary audio input cable to verify normal operation. If the auxiliary audio input activates the voice modulation indicator normally, the CM-183RT microphone may need to be repaired or replaced.
- The M-216 transmitter must be returned to COMTEK for service if the auxiliary input test does not activate the voice modulation indicator.

M-216 TROUBLE SHOOTING (Continued)

Possible Causes of Noisy Audio

1. Excessive Distances

Operating at a distances greater then 200 ft. may cause excessive noise.

2. Channel Selection

Operating on non-companded channels 1-40 will inherently have much noisier characteristics. Companded channels 41-60 will produce the best signal-to-noise performance.

3. Gain Problem

Check the microphone gain setting on the M-216 transmitter for normal operation with the “voice” modulation indicator (See page 2 section d.) Low modulation will render poor signal-to-noise ratio.

4. Channel Interference

Monitor the PR-216 receiver with the headphone plugged in and with the transmitter turned “OFF” on the channel that the transmitter is tuned to. Check the PR-216 receiver status indicator LED. If a steady slow flash is indicated, the receiver is receiving a signal on the transmitter channel and a new channel must be selected. If the status indicator LED on the PR-216 receiver is illuminated continuously and noise is no longer heard, then the channel is clear and channel interference is not the problem.

5. Transmitter Power and Receiver Sensitivity

Check the M-216 transmitter for normal R.F. power and the PR-216 receiver for normal R.F. sensitivity. This can easily be done by range checking the receiver and transmitter with the microphone cord antenna removed from the transmitter. Turn on the transmitter and place it on a non-metallic table. Turn on the receiver and plug in the headphone cord into the receiver like it would normally be used. Then walk away from the transmitter while listening for noise build-up just before the squelch action takes place. A distance of 30-50 ft. should be obtained. Use companded channels 41-60 for this test. If the receiver and transmitter do not pass this test, both receiver and transmitter must be returned to COMTEK for service.

M-216 SPECIFICATIONS

Audio Input:

- Microphone input impedance for electret type microphone - 3000 ohm
- Aux/Line input impedance - 10 k ohm at 0 dB nominal

Connectors:

Microphone - Micro-mini mono 2.5 mm

Auxiliary - Mini stereo 3.5 mm

Audio: Tip and sleeve

Battery Charging: + Tip, - sleeve

9 volt DC input: + Ring, - sleeve
(with current limiting)

Controls and Indicators:

- Synthesized channel selection switches
- Power On/Off switch
- Optional microphone muting switch
- Audio input gain control
- Power/Battery status indicator
- Audio (voice level) modulation indicator
- Companded auto/off switch (optional)

Frequency Response:

80 Hz to 10 kHz

Audio Distortion:

Less than 1% at 80% modulation

Modulation Limiter:

Soft compressor with 30 dB linear overload protection, attack time - less than 1 ms, recovery time - 10 ms

Frequency Modulation:

- 10 kHz deviation

Operating Radio Frequency:

57 synthesized frequencies in the 216-217 MHz LPRS band under FCC part 95

Out-of-Band Emissions:

Better than 45 dB below carrier

R.F. Stability:

20 ppm XTL controlled
Digitally synthesized

RF Power Output:

10 mW to antenna system

Antenna System:

Body-worn microphone cord, or whip plugged directly into microphone connector when auxiliary input is used

Current Drain:

18 mA constant current

Battery:

- 9 volt alkaline Eveready 522 or equivalent for up to 30 hours of operation
- 9 volt Nickel-Metal Hydride rechargeable battery for up to 10 hours of operation

Dimensions:

1 1/16" x 2 1/4" x 3 1/2"
(27 mm x 57 mm x 89 mm)

Weight:

5 ounces (140 grams)

FCC Compliance:

Certification under Part 95

NOTE: Specifications subject to change without notice or obligation

M-216 WARRANTY AND SERVICE

Warranty

COMTEK warrants this product to be free from defects in workmanship and material under normal use and conditions for a period of one year from date of original purchase. Items such as batteries, neckloops, and cords are not covered by the warranty. Damage due to misuse, ill treatment and unauthorized modification and repairs are not covered by this warranty. COMTEK is not liable for consequential damages arising out of any failure of the equipment to perform as intended. COMTEK shall bear no responsibility or obligation with respect to the manner of use of any equipment sold by it. COMTEK SPECIFICALLY DISCLAIMS AND NEGATES ANY WARRANTY OF MERCHANTABILITY OR FITNESS FOR A PARTICULAR PURPOSE OF SUCH EQUIPMENT INCLUDING, WITHOUT LIMITATION, ANY WARRANTY THAT THE USE OF SUCH EQUIPMENT FOR ANY PURPOSE WILL COMPLY WITH APPLICABLE LAWS AND REGULATIONS.

Service Policies

Warranty repairs must be done by COMTEK. Only factory technicians are authorized to perform warranty service on the M-216 transmitter. Before returning the M-216 for service, a Return Authorization Number should be obtained from the service department by calling 1-800-496-3463 or 1-801-466-3463. Return the unit to the factory with the original or comparable packing. COMTEK will pay for insurance and ground return shipping costs in the United States for all warranty service.

COMTEK®