

CONTENTS

INTRODUCTION	1
UNPACKING	1
VISUAL INSPECTION	1
SPECIFIC POINTS	1
IMPORTANT SAFETY INSTRUCTIONS	3
POWERING	4
TECHNICAL SPECIFICATION	6
EQUALISATION CURVES	9
BLOCK DIAGRAM	10
CONNECTOR PANEL	11
CONNECTIONS	12
INPUT MODULE	14
OUTPUT MODULE	16
ADJUSTMENTS AND CALIBRATIONS	18
AD100-09 POWER SUPPLY UNIT	21
CUSTOMER NOTES AND FACTORY MODIFICATIONS	22
TECHNICAL LIBRARY	23

INTRODUCTION

Unpacking

If there are any signs of damage to the outside of the carton, please notify us or your supplier immediately, regardless of the unit's apparent physical condition. This is in case a claim has to be made at a later date because of previously undetected transit damage. The packaging material should not be discarded until the mixer has been acceptance tested and a suitable transit/storage case is available for secure, safe storage.

Visual Inspection

Identification - please make a separate note of the serial number for your own capital equipment records. Ensure that it agrees with the number on the invoice/packing note. The serial number label is on the back cover, adjacent to the battery compartment.

Temperature - check the meter glasses for condensation. If the package has been in transit during cold weather, leave the mixer for at least 12 hours to allow it to return to normal room temperature. Any measurements or subjective tests then made, will be to a known temperature reference.

Specific Points

Battery compartment - the mixer has an integral battery compartment to accept 6size-AA cells, and is built into the transversal extrusion.

DC-DC converter - is mounted on the right hand module. Care must be taken when removing the module, because some wire looms connect from the module to the base boards.

In order to facilitate the testing and calibration of all modules, a set of two extender modules is available from the factory.

Connectors - for convenience, the connector panel is labelled for reading from above. All connectors are in line with their corresponding module.

Fuse - to protect the mixer and internal power supply is mounted on the power supply/converter board. Access is gained by removing the DC-DC converter module. A resettable polyfuse is fitted, therefore maintenance should not normally be required. The fuse resets after removal of the fault causing the overload.

Limiter threshold - is set at the factory at +8dBu (PPM 6), but an internal preset potentiometer allows adjustment to any other level above 0dBu. The limiters are to be found on the output module printed circuit board.

Microphone powering - the mixer will remain unconditionally stable if the powering on unterminated input channels is switched off - this also improves the noise performance and crosstalk. Powering - 48V phantom may be selected before or after the microphone is connected to the module.

Module fix screws - Hexagon head screws are used to fix the modules and back cover. The size is 1.5mm HEX A/F with a 2.5M thread. If it becomes necessary to remove modules or back cover it is strongly advised using a good quality hexagonal head driver. Use of a screwdriver, however desperate, is not recommended.

We wish you many trouble-free hours of use from your mixer. As a company, we are fully committed to BS EN ISO 9001. Should you have any problem or require any further information on mixers or the M-S microphone technique, please do not hesitate to contact us on 01543 375351 or by fax on 01543 361051.

WARNING

IMPORTANT SAFETY INSTRUCTIONS

The user of electrical products must be familiar with their potential dangers, and fundamental precautions must always be taken. Please read the following text carefully.

Power supply units manufactured by Audio Developments Ltd are not user serviceable. There are no user-serviceable parts associated with any such power supply unit.

THE OUTER COVERS MUST NOT BE REMOVED

Such a power supply unit is solely for use with audio mixers and sound processors - hereafter called the equipment - manufactured by Audio Developments Ltd. Always use a cord set accepted by a National Approved Body.

EARTHING/GROUNDING: When using an external power supply unit that is connected to the mains supply to drive the mixer it must be **CONNECTED TO EARTH**.

In certain types of malfunction or breakdown, earthing provides a path of least resistance for electric current and considerably reduces the risk of electric shock.

DANGER: Incorrect connection of the equipment grounding/earthing conductor can result in the risk of electric shock. Where possible obtain a pre-wired mains lead from a reputable supplier with the correctly fitted mains connector for the type of mains outlet in use; otherwise, one correctly wired and checked by a qualified electrical engineer. If your mains lead is not suitable for the mains outlet, have the correct plug fitted by qualified personnel.

The **MAINS PLUG** of this equipment is the primary disconnect device. Therefore, in the final application, ensure it remains close to the equipment and easily accessible.

POWERING

The mixer may be powered from either internal cells or an external DC power source.

The integral battery compartment requires a total of 6 size-AA cells. Access is gained via a captive lid which is retained by one 90-degree-turn buckle. The lid hinges outwards from the bottom panel. When installing new cells please ensure they are inserted with the correct polarity rotation.

Either conventional dry, or rechargeable nickel-cadmium cells may be used. However, no recharge facility for ni-cads exist within the mixer. This must be carried out externally.

When driving the mixer from an external power source, PIN 1 is the 0V connection and a voltage in the range +9V to +15V DC should be supplied to PIN 4. The power source should be capable of delivering approximately 400mA - allowing some capacity for phantom powering.

If an external power supply unit (PSU) is to drive the mixer, a current capability of at least 400mA is required. It is poor practice to run a PSU at its limit, therefore we recommend a minimum of 600mA.

Audio Developments AD100-09 PSU is a suitable unit.

WARNING: When NOT using the PSU (AD100-09) supplied for the mixer, ensure your 4-pin XLR is correctly wired to match the POWER IN connector. Failure to do so may result in the breakdown of the internal DC-DC converter. Make this check even if using a PSU which may have been supplied to you in the past, eg AD100-06.

THIS PAGE IS BLANK

TECHNICAL SPECIFICATION - ELECTRICAL

REFERENCE 0dB=775mV at 1kHz unless otherwise stated.

MAX GAIN	MIC LINE	70dB 6dB	LINE	40dB
MAX INPUT LEVEL	MIC @ MAX GAIN -44dBu @ MIN GAIN + 6dB LINE @ MAX GAIN -14dBu @ MIN GAIN +20dB STEREO-RETURN +18dBu			
INPUT IMPEDANCE	MIC LINE STEREO-RETURN	>2k5R >6k5R >100kR		
MIC POWERING	48V PHANTOM			
MAX OUTPUT	+23dBm +18dBm	L-R H'PHONE	TRANSFORMER BAL MONITOR	UNBAL
OUTPUT IMPEDANCE	<60R <20R	L-R MONITOR		
FREQUENCY RESPONSE	0: -1dB 0: -1.5dB	L-R MONITOR PATHS		
HARMONIC DISTORTION	<0.05% @ 1kHz @ 0dBm OUTPUT <0.15% @ 40Hz to 15kHz @ +15dBm OUTPUT			
OVERLOAD INDICATOR	ILLUMINATES @ +15dBu at PRE-FADER POINT			
CROSSTALK	<-70dB 40Hz to 15kHz INTERGROUP & INTERCHANNEL			
NOISE	MIC <-126dB EIN 20Hz to 20kHz; 200R SOURCE LINE <77dB SNR 20Hz to 20kHz 0dBu IN & OUT			
EQUALISATION	HF: ±10dB @ 10kHz LF: ±10dB @ 100Hz MF: ±15dB CENTRE FREQUENCY 2k5Hz Q=1.2 HPF: PRE-TRANSFORMER 12dB/OCTAVE -3dB @ 150Hz -3dB @ 90Hz			

OUTPUT LIMITER

THRESHOLD	+8dB
RATIO	7:1
ATTACK	4mS
RELEASE	250mS

CURRENT CONSUMPTION

130mA (4 INPUT) 12V DC SUPPLY

TECHNICAL SPECIFICATION - MECHANICAL

SIZE

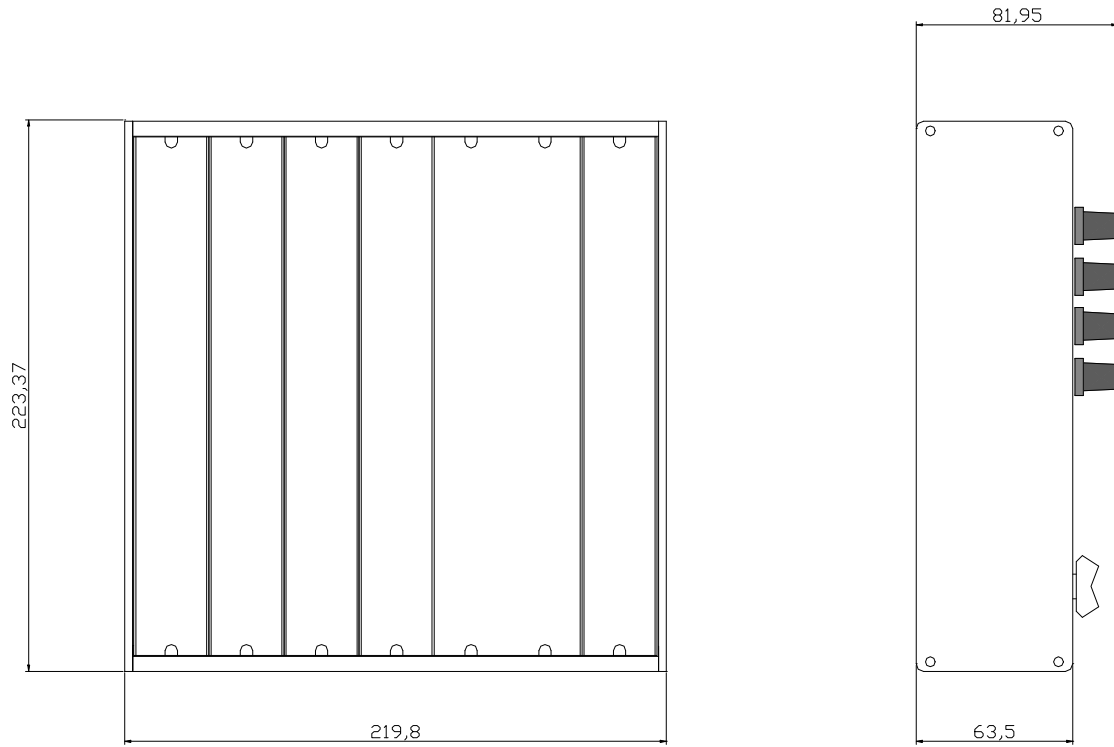

ALL DIMENSIONS IN MILLIMETRES

WEIGHT 2.3 Kg (Excluding batteries)

EQUALISATION CURVES

AD 114 HIGH AND LOW EQ

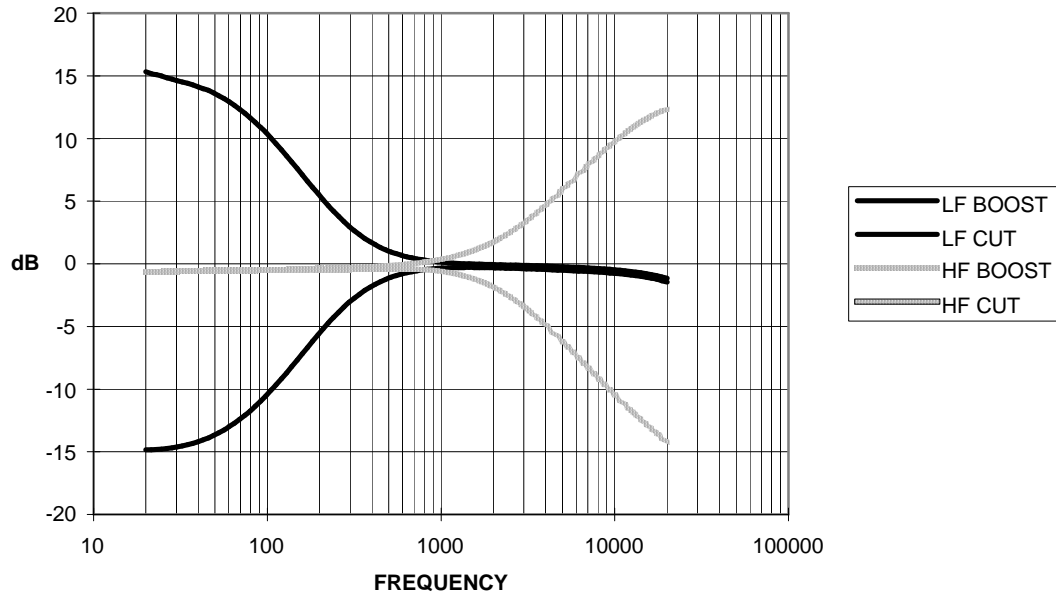

AD 114 MID EQ AND HPF

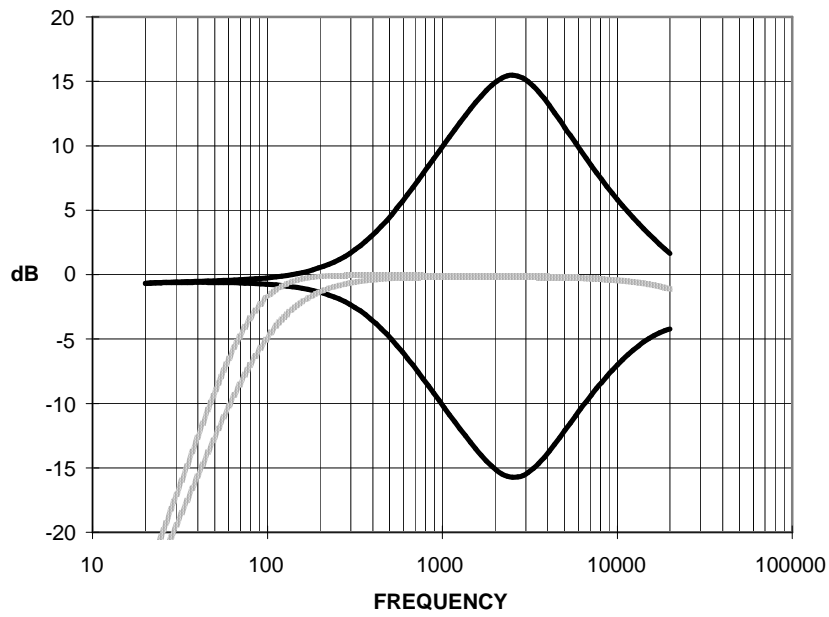

BLOCK DIAGRAM

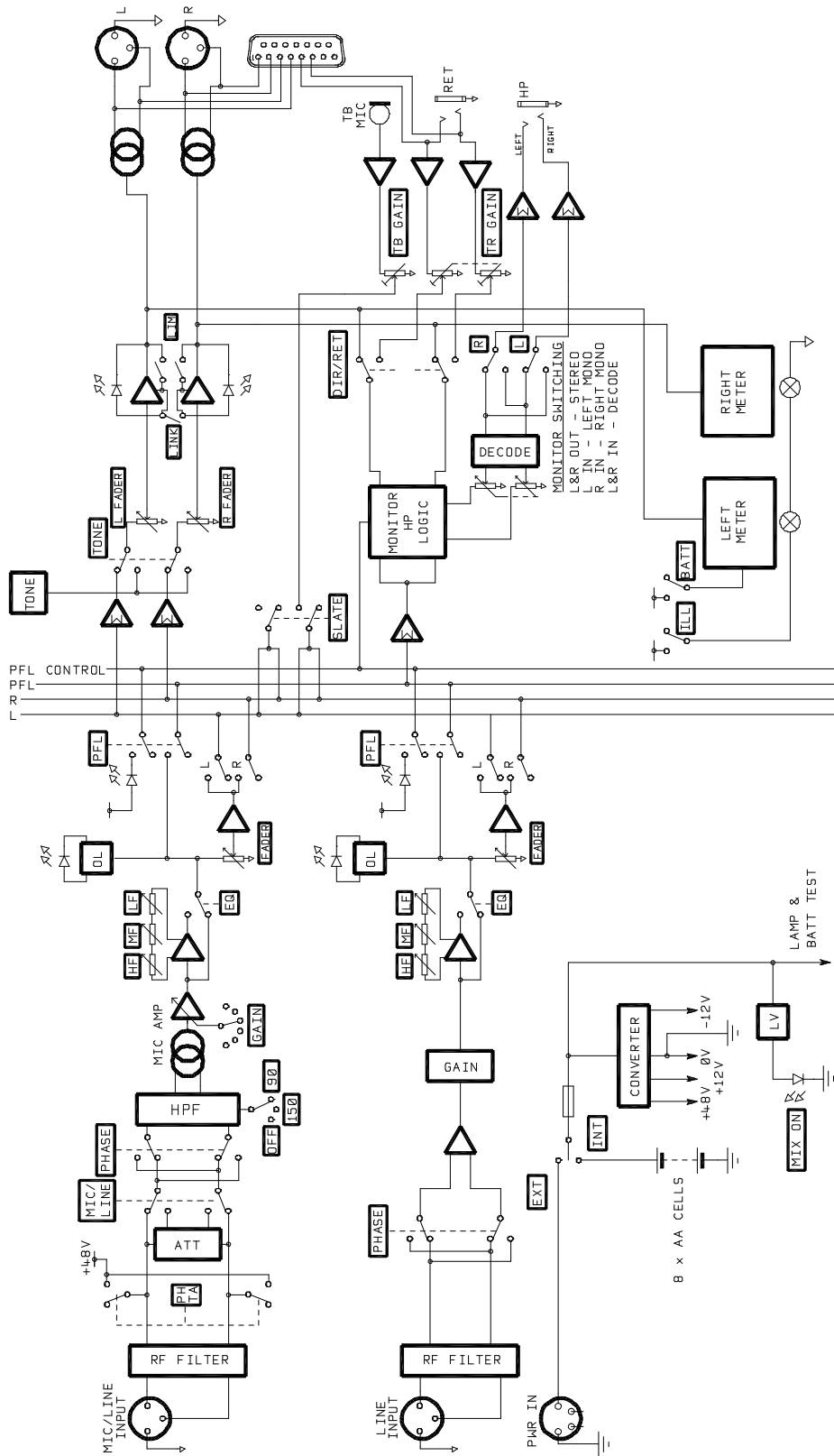

CONNECTOR PANEL

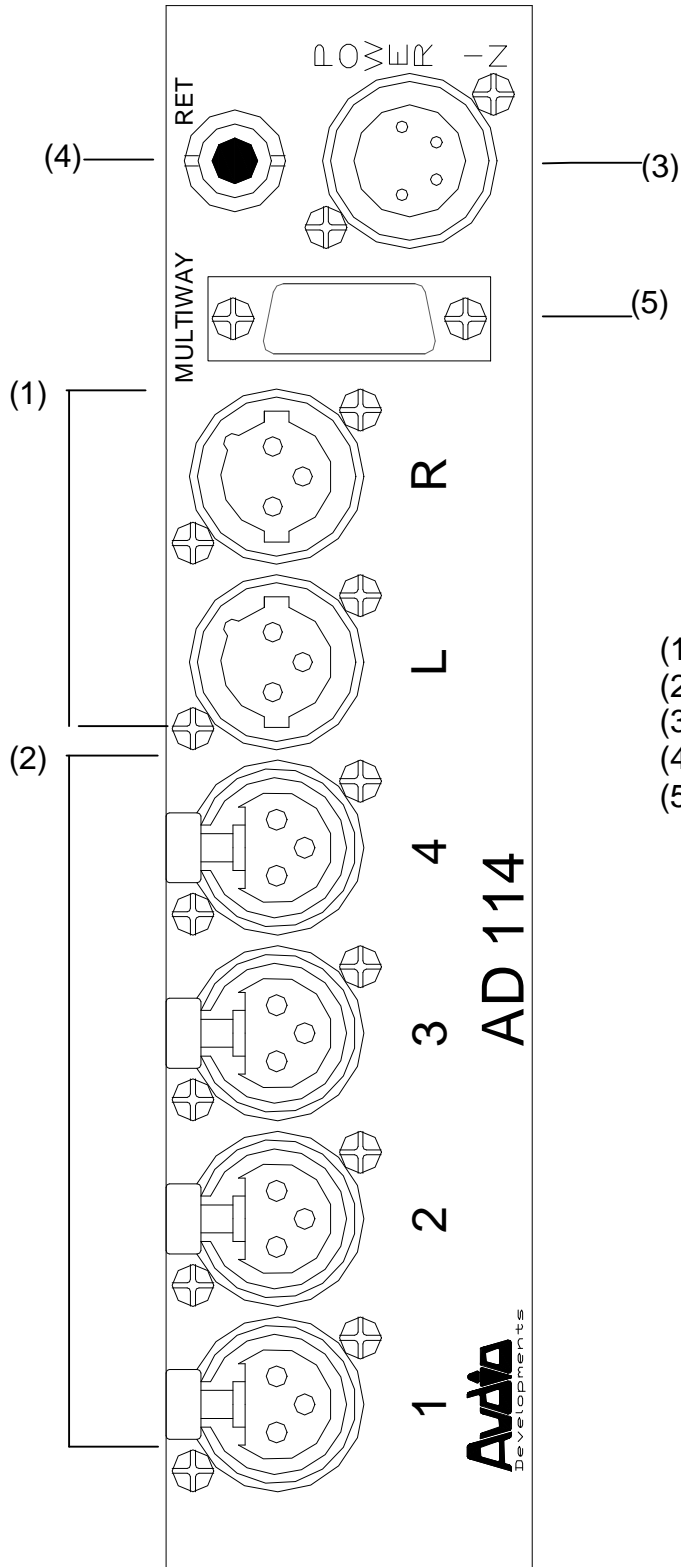

- (1) Stereo output XLRs (L & R)
- (2) Mic/Line input XLRs
- (3) External DC power input
- (4) Stereo-return jack
- (5) Subsidiary connector

All input and output impedances and levels are to be found in the TECHNICAL SPECIFICATION.

All inputs to, and outputs from AD114 are to be found on the connector panel except for the monitor output, which is mounted on the bottom panel facing the operator.

Module connector (2) accepts balanced microphones and balanced line-level inputs.

XLR (input & output)	Pin 1	Shield
	Pin 2	Signal +
	Pin 3	Signal -

In the case of unbalanced line-inputs and outputs, pins 1 & 3 should be connected. This will not lead to a loss of level.

Main stereo (1) outputs are transformer balanced, and are at line-level.

The stereo tape-return enters the mixer on a standard, 'A' type stereo jack (4); left and right. Each input is unbalanced.

Unbalanced headphone monitor output appears on an 'A' type stereo jack. This output is capable of driving 25R at 0dBu.

STEREO UNBALANCED JACK

Tip	Left signal
Ring	Right signal
Sleeve	Shield

The 15-pin D connector, Multiway (5), carries output and return signals to and from external device within one cable.

NORMAL	IDC		
Pin.1	(1) Chassis	Pin 8	(15) Chassis
Pin 2	(2) Spare	Pin 9	(2) Output Left +
Pin 3	(3) Spare	Pin 10	(4) Output Left -
Pin 4	(5) Spare	Pin 11	(6) Output Right +
Pin 5	(7) Spare	Pin 12	(8) Output Right -
Pin 6	(11) Spare	Pin 13	(10) Return Left
Pin 7	(13) Spare	Pin 14	(12) Return Right
		Pin 15	(14) Spare

A three-position rocker switch BATT/EXT selects either internal batteries or an external DC source. Power to the mixer is confirmed by the MIX ON LED on the power module. The LED flashes when the internal voltage falls below the safe operating level of 6.7V.

External powering of the mixer is via a 4-pin XLR (3).

XLR	Pin 1	OV	Pin 3	NC
	Pin 2	NC	Pin 4	9V - 15V DC

A suitable external power supply is Audio Developments' AD100-09, but any external DC source must be capable of delivering 600mA at 12V.

MICROPHONE/LINE INPUT MODULE

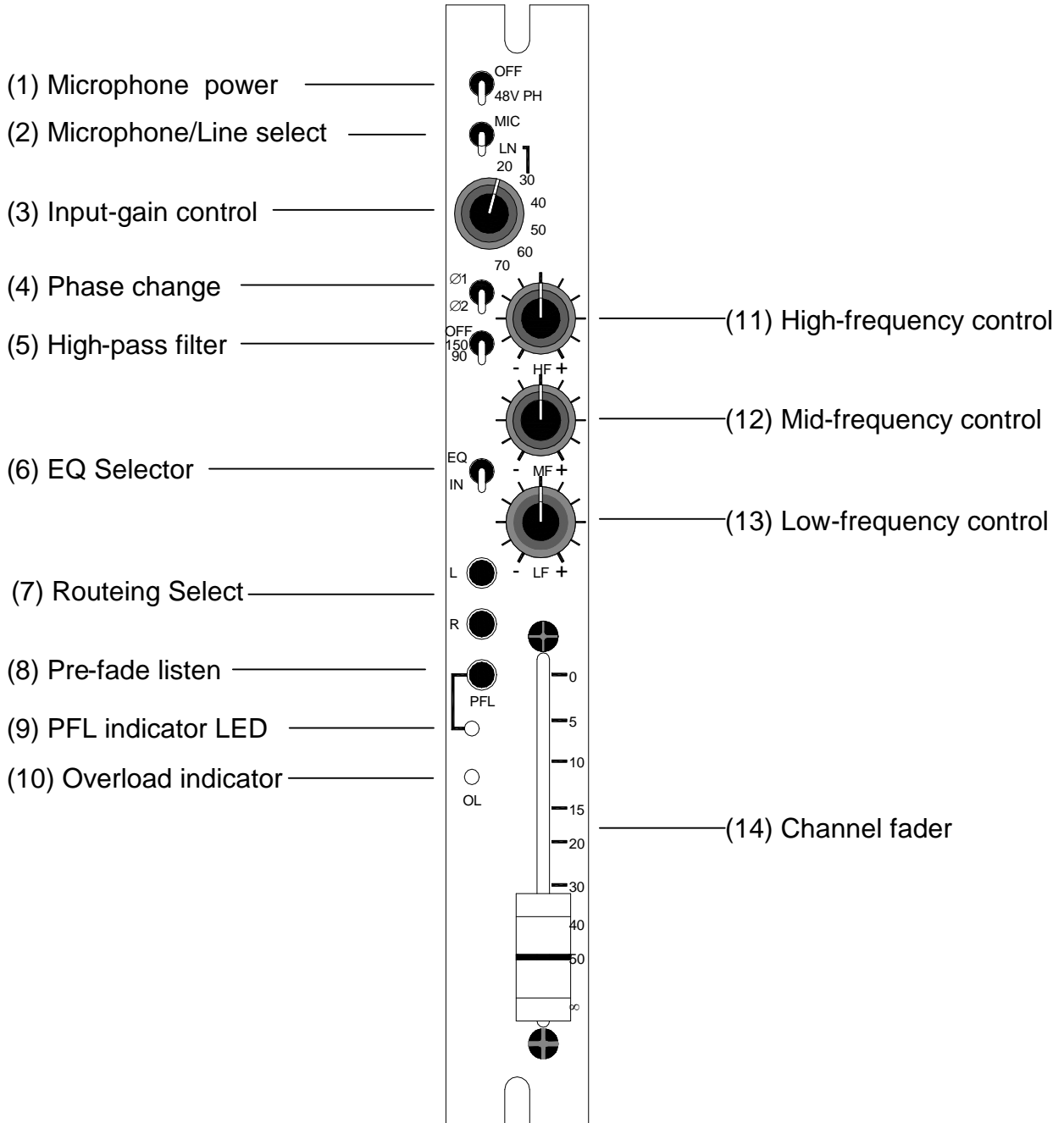

The Microphone/Line input module functions are as follows: Switch (1) selects 48V phantom power for condenser microphones. Powering may be selected before or after connecting the microphone, but switch off all powering on unterminated modules to ensure unconditional stability of the mixer. For complete safety of external equipment, switch off microphone power before connecting a line-level signal.

Phase change (4) is pre transformer and operates on microphone and line inputs. \emptyset_1 is the normal position.

The high-pass filter is pre transformer and, similarly, operates on microphone and line inputs. In this position the filter protects the transformer from low-frequency saturation caused by wind, traffic, air conditioning etc. Operating frequencies are to be found in the TECHNICAL SPECIFICATION. The high-pass filter operates independently of the equaliser.

The input gain of the microphone amplifier is set by the 6-position switch (3). The range of this control is 50dB in 10dB steps. For line-level signals, an input attenuator is inserted via switch (2).

Following the microphone amplifier is the simple, but effective, equaliser as used in the AD245 - selector switch (6). Amplitude controls are HF (11) MF (12) and LF (13).

Two push-button switches - (7) routes the module's signal proportionately between the left and right mix busses.

Pre-fader listen (8) with its LED indicator (9) routes the module's signal to the monitor/PFL mix buss for auditioning on headphones.

An overload LED (10) illuminates 3dB before clipping at the input to the fader.

The Penny & Giles fader (14) is calibrated at the fully open position. Faders on adjacent modules can be coupled for stereo operation by the use of standard ganging clips.

Line input module - The facilities incorporated in this module are identical to that of the Microphone/Line module except there is no microphone powering, no microphone/line select and input switched gain control. The latter is replaced by a rotary potentiometer with a gain variation range of +/- 6dB

OUTPUT MODULE

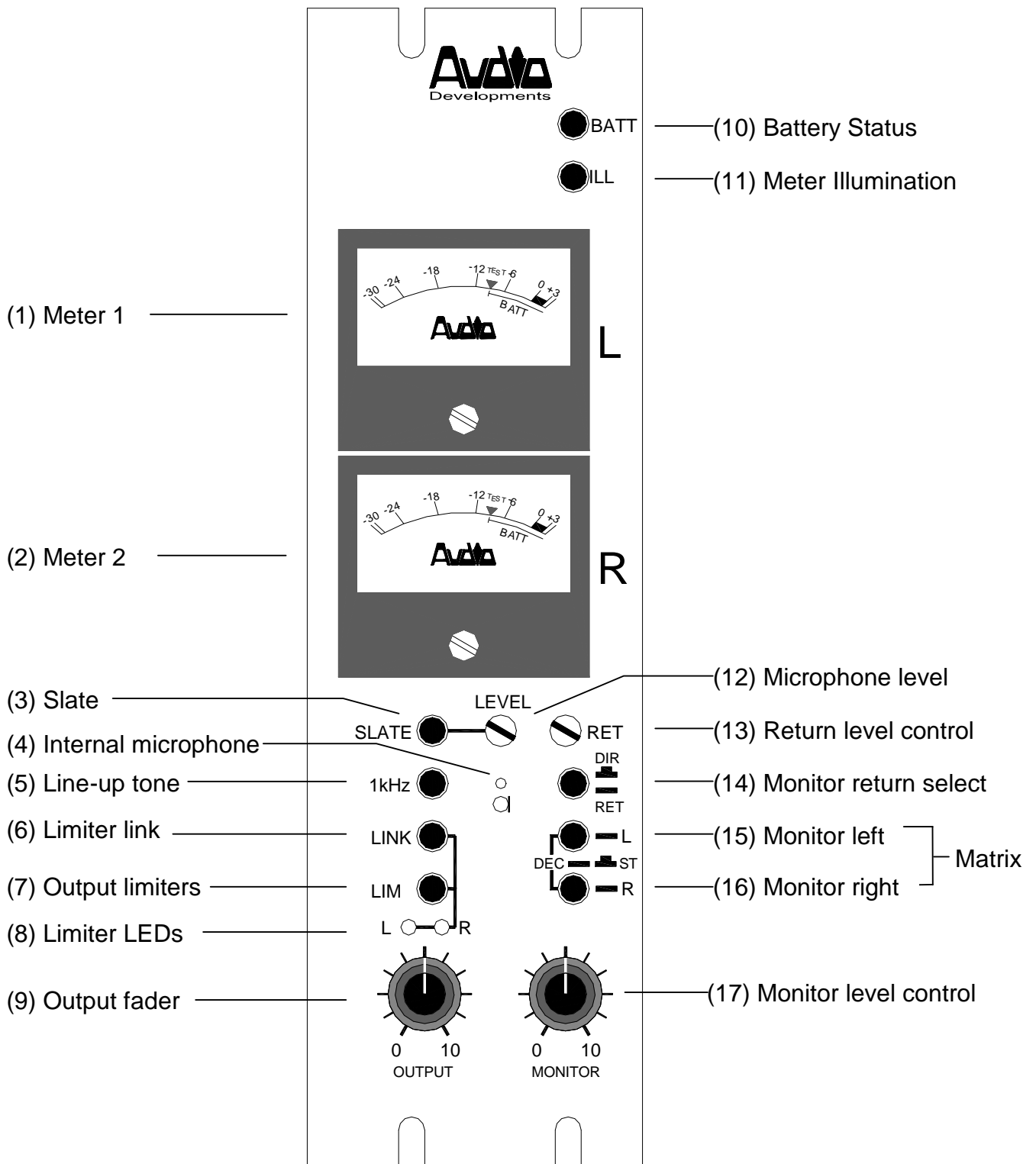

This module controls the level of main and monitor output signals and metering of the output signals. Calibration is achieved when the stereo output level control (9) is at maximum.

The upper meter (1) reads left output, the lower meter (2) right output.

Battery status is read on the upper meter by BATT (10) and the meters may be illuminated by ILL (11) - overuse of this function will rapidly drain the batteries. When the internal voltage drops below a safe operating level the battery status reading is at the lower limit of the BATT mark. On a VU meter this is at 0VU

The main output signal is metered and monitored after the output level control and limiters.

A pair of limiters may be switched in to the main output - LIM (7) - and linked for stereo operation - LINK (6). LEDs (8) indicate when limiting is taking place. The factory setting for onset of limiting is +8dBu at the main outputs. Refer to Adjustments and Calibrations section of this manual, if a different setting is required.

Line-up tone, when selected (5), replaces the normal signals on the main output. Line-up tone is calibrated on the (BBC-scaled) meters to PPM4, giving a line output level of 0dBu with the output faders set to maximum. On a VU scaled meter the calibration is 0VU giving a line output level of +4dBu.

The remaining controls are associated with headphone-monitoring of signals from the mixer - internal signals (DIR) or tape-return (RET) maybe selected (14): these signals may be either in the L-R domain or the M-S domain. When switches (14), (15), and (16) remain unselected the main-output signal from the mixer appears on the headphones. If SW (15) is selected, the left-output signal appears on both earpieces; if SW (16) is selected, the right-output signal appears on both earpieces. If switched (15) + (16) are selected, a matrix amplifier is inserted across the monitor output: when the main output is in the L-R domain, the matrix will enable mono compatibility to be assessed on the left earpiece and out of phase components to be checked on the right earpiece. When working entirely in the M-S domain, the matrix will transform the mixer output into the L-R domain for monitoring purposes. Selection of RET (14) will allow these functions to be performed on a tape-return signal. The level of the monitor signal is controlled by potentiometer (17). The level of the return signal is controlled by a present potentiometer (13). This allows for calibration of the return signal. For a 0dBu signal, the system is calibrated when the preset is fully counter-clockwise. From that point 20dB gain is available for lower level signals.

The signal from the internal microphone (4) allows the mixer operator to add a voice signal to the main output by operating the switch marked SLATE (3). The level is controlled and set by preset potentiometer (12).

ADJUSTMENTS AND CALIBRATIONS

Meters - are to broadcast specification and either a VU or a PPM may be selected. A choice of 3 scales is available for the PPM: BBC, N10, SDR.

Line-up-tone oscillator - the preset (VR3) that adjusts its level at the output of the mixer is mounted on the output module printed circuit board.

Low-battery indicator - the preset (VR10) associated with this facility is also mounted on the output module printed circuit board. The low reading is set at the factory and corresponds to a set of batteries having discharged to 6V. On a VU meter, low volts is at 0VU. On a PPM meter it is indicated by a separate marking: yellow on a BBC scale and red on an N10 and SDR scale.

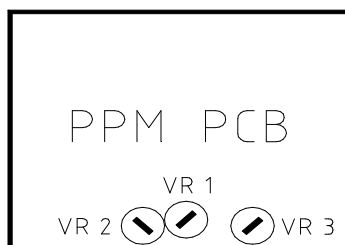
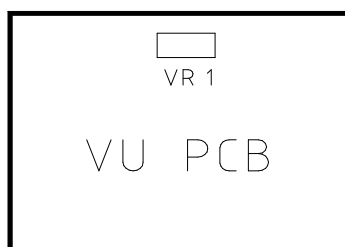

14991201

VU meter - there is one preset, on the VU meter PCB, for meter adjustment. Set an input module for a line input and introduce a 1kHz tone from an audio signal generator. Adjust levels to achieve a reading of +4dBu, at a main output, on an AC millivoltmeter - measured across pins 2 & 3 on the output XLR. Select the meters to L-R and adjust the preset to give a reading of 0VU.

PPM meter - the driver PCB has three calibration controls (presets). VR1 adjusts the reference level, VR2 and VR3 adjust the 'law' of the meter. VR2 adjusts the upper sector of the scale and VR3 adjusts the lower sector. To initiate calibration, set each preset to its mid position.

BBC scale - using the tone generator and millivoltmeter as described above, adjust mixer levels for a reading of 0dBu, on the millivoltmeter, from a main output. Select the meters to L-R and adjust VR1 for a reading of 4. Increase the output signal to +8dBu and adjust VR2 for a reading of 6. Decrease the output signal to -8dBu and adjust VR3 for a reading of 2. Repeat this procedure until an accurate set of readings is obtained without further adjustment to any of the presets being required. Now check all points 1 to 7 on the scale to determine whether they are within specification.

N10 scale - for a meter calibration of TEST = 0dBu. With a main-output signal of -6dBu, adjust VR1 to give a meter reading at -6. Increase the signal to +6dBu and adjust VR2 to obtain a meter reading at +6. Lower the output signal to -18dBu and adjust VR3 to obtain a meter reading at -18. Repeat this procedure to obtain an accurate reading at each of these three points. Now check the calibration of all meter points.

SDR scale - with a main-output signal level of -6dBu, adjust VR1 to obtain a reading of -12. Increase the output signal to +6dBu and use VR2 to obtain a reading of 0 on the meter. Lower the output signal to -18dBu and adjust VR3 to give a reading of -24. Repeat the procedure to obtain an accurate reading at each of these three points. Now check the calibration of all meter points.

Main-output limiters - calibration involves two presets per output. Using the 'L' output as the example ...

Biasing and threshold are adjusted as follows: VR5 biases the limiter circuit to the point of correct operation and VR4 sets the threshold. (Labelled SET 0 and THR respectively.)

With no signal present, VR5 should be adjusted to give a reading in the range -1.5V to -2.5V at PIN 14 of IC 2. VR4 should be adjusted to give a reading in the range -2.5V to -3.5V at PIN 10 of IC2.

Apply a signal at 1kHz to the mixer to give a level of 0dBu at 'L' output. Then select the limiter function and adjust VR5 until the output signal starts to fall (typically 0.2dB). The DC voltage at PIN 14 of IC 2 should be approximately -2.0V.

After setting VR5, adjust the output signal to just greater than +8dBu with the limiter deselected. Introduce the limiter and adjust VR4 until the output signal falls to +8dBu. This is the THRESHOLD setting. (If a different threshold setting is required, alter the signal levels accordingly.) The DC voltage at PIN 10 of IC 2 should be approximately 0.6V different from that at PIN 14.

The right output can be set using the above procedure, but the preset and IC numbers change to correspond with the output being calibrated.

The link function has no individual setting of its own. To ensure this works within specification it is important that L and R outputs are set up as a pair. After following the above procedure, the DC voltages at PINS 14 and PINS 10 of the ICs should be identical. (Tolerance $\pm 0.1V$ with typical figures at PIN 10 of -2.6V and PIN 14 of -2.0V)

**POWER SUPPLY UNIT
TYPE AD100-09**

The AD100-09 mains POWER SUPPLY UNIT is suitable for driving most of AUDIO DEVELOPMENTS' range of portable audio mixers. This PSU is a single-rail device providing 500mA of current at +14v DC potential and is used as a substitute for battery power with mixers containing an internal DC-DC converter.

The AD100-09 may be powered from either a 110/120v AC source or a 220v/240v AC source. Ensure that the AC Voltage Selector Switch on the front panel is in the correct position for the source in use. Operating the equipment at the wrong voltage could be hazardous. Care must be taken to connect the LIVE, NEUTRAL and EARTH pins of the PSU's IEC mains connector to the corresponding terminals associated with the AC source. The ON/OFF switch contains an indicator that illuminates when the PSU is operational.

FOR SAFETY REASONS, AD100-09 POWER SUPPLY UNIT MUST BE CONNECTED TO MAINS EARTH. Any maintenance to the PSU or its mains cable assembly should be performed by a qualified engineer.

CHARGING: If nickel-cadmium cells are fitted in an AD140 series mixer, they may be recharged in situ from AD100-09 power supply - whether the mixer is in use or not. (Maximum current is set at 250mA - in addition to the 500mA of current supplying the audio electronics.) The charging circuit has its own ON/OFF slide switch and LED indicator. **DO NOT ACTIVATE THE CHARGE CIRCUIT UNLESS THE MIXER IS FITTED WITH NICKEL-CADMIUM CELLS.**

FUSES: Two 20mm ANTI-SURGE fuses protect AD100-09 against fault conditions. Should either fail, it is strongly recommended that the cause be traced. Refer to the TECHNICAL LIBRARY. Only suitably qualified personnel should service the power supply unit. The fuse holder on the front panel contains the mains fuse.

250mA HRC TYPE T 240v AC

For continued safety the specified fuse link must be fitted in the mains fuse holder when a replacement is required. Ensure it is of a type approved by a National Approved Body.

DC-OUTPUT XLR	PIN 1	0v	PIN 3	NOT CONNECTED
	PIN 2	CHARGE	PIN 4	+14vDC

DO NOT REMOVE THE OUTER COVERS

NOTE: The power supply unit should be serviced by a suitably qualified engineer. Only genuine spare parts with identical specification must be used.

It is DANGEROUS to change the specification or modify the product in any way.

CUSTOMER NOTES AND FACTORY MODIFICATION

TECHNICAL LIBRARY

MIC/LINE PARTS LIST

Item	Part Number	Qty	CAD Part Ref.	Ref. Designator
1	74-130-001	1	AMP-064V	IC2
2	74-120-010	1	AMP-393V	IC5
3	74-920-001	1	AMP-MIC	AMP-MIC/1
4	18-001-256	6	CAPCER100ND	C35, C36, C37, C38, C39, C40
5	18-001-321	1	CAPCERU#47P	C28
6	18-015-507	3	CAPELEC1.0G1	C3, C4, C25
7	18-015-411	2	CAPELEC4.7E1	C15, C16
8	18-013-022	1	CAPELEC102B1	C8
9	18-045-019	2	CAPPES470N-H	C2, C32
10	18-001-241	2	CCU#2N2	C43, C44
11	18-001-227	1	CCU#150P	C21
12	18-010-808	1	CEA4.7-100	C27
13	18-010-114	1	CEA47-10	C41
14	18-010-217	2	CEA150-16	C24, C26
15	18-013-316	1	CER100-25	C5
16	18-013-219	4	CER330-16	C30, C31, C33, C34
17		1	CONSWIR	101
18	18-045-007	1	CPE4N7-63	C22
19	18-045-013	1	CPE47N-63	C20
20	18-045-108	1	CPES#6N8	C19
21	27-023-002	1	DIN16MRA	CON1
22	72-010-001	2	DIO-1N4148	D1, D2
23	22-505-102	2	IND-U0.4#220U	L1, L2
24	40-115-001	2	LED-5MM#RED	LED1, LED2
25	27-025-063	1	MOL3PIN	CON2
26	72-022-001	1	PNP-BC559B	TR5
27		1	POTFAD2#VR4	FADER
28		3	POTMOL#50KLN	VR1, VR2, VR3
29	82-126-003	3	PUS204	S7, S8, S9
30	70-031-036	2	RESM1/8#33	L3, R24
31	70-031-048	1	RESM1/8#100	R25
32	70-031-060	1	RESM1/8#330	R26
33	70-031-040	6	RESM1/8#47R	R42, R46, R59, R60, R61, R64
34	70-031-056	1	RESM1/8#220R	R6
35	70-031-073	1	RESM1/8#1K1	R27
36	70-031-076	1	RESM1/8#1K5	R38
37	70-031-078	1	RESM1/8#1K8	R37
38	70-031-079	1	RESM1/8#2K	R39
39	70-031-084	2	RESM1/8#3K3	R5, R7
40	70-031-086	1	RESM1/8#3K9	R28
41	70-031-092	4	RESM1/8#6K8	R1, R8, R53, R62
42	70-031-096	2	RESM1/8#10K	R31, R65
43	70-031-104	8	RESM1/8#22K	R10, R11, R12, R29,

		R55, R57, R58, R63
44	70-031-108	1 RESM1/8#33K R48
45	70-031-112	4 RESM1/8#47K R43, R45, R66, R67
46	70-031-120	6 RESM1/8#100K R34, R36, R44, R47, R49, R51
47	70-031-132	1 RESM1/8#330K R40
48	70-031-136	1 RESM1/8#470K R41
49	82-257-801	1 ROT1061 SW5
50	81-217-502	4 TOG06 S1, S2, S4, S6
51	81-227-502	1 TOG08 S3
52	86-010-101	1 TXA-A187A1C T1

OUTPUT L/H BOARD PARTS LIST

Item	Part Number	Qty	CAD Part Ref.	Ref. Designator
1	74-120-001	1	AMP-061CP	IC2
2	74-120-002	1	AMP-062CP	IC3
3	74-120-003	1	AMP-071CP	IC1
4	18-001-256	2	CAPCERU#100N	C1, C2
5	18-045-017	2	CAPCERU#220N	C7, C20
6	18-001-205	1	CAPCERU#2P2	C4
7	18-015-507	2	CAPELEC1.0H1	C6, C19
8	18-010-213	1	CAPELEC330C1	C3
9	18-001-321	2	CCU#47P	C16, C18
10	18-015-505	1	CER.47L-50	C14
11	18-015-411	2	CER4.7-35	C15, C17
12	18-015-213	1	CER10L-16	C9
13	18-015-217	2	CER47L-16	C5, C8
14	18-045-009	2	CPE1N-63	C10, C13
15	27-023-002	1	DIN16MRA	CON1
16	72-010-001	7	DIO-1N4148	D1, D2, D3, D4, D5, D6, D7
17	72-025-005	1	FET-BF256A	TR3
18	40-615-001	1	LED-5X2#	LED1
19	44-001-001	1	MIC1	MC1
20	72-021-001	1	NPN-BC549C	TR4
21	72-022-001	3	PNP-BC559B	TR1, TR2, TR5
22	52-040-416	1	POTA2#	VR2
23	52-055-416	1	POTA2#50K	VR1
24	82-126-003	3	PUS204	S1, S2, S4
25	82-146-002	1	PUS404	S3
26	70-031-048	2	RESM1/8#100R	R5, R9
27	70-031-054	1	RESM1/8#180R	R15
28	70-031-069	1	RESM1/8#750R	R16
29	70-031-073	1	RESM1/8#1K1	R12
30	70-031-081	1	RESM1/8#2K4	R10
31	70-031-090	2	RESM1/8#5K6	R7, R30
32	70-031-096	9	RESM1/8#10K	R1, R2, R6, R18, R19, R23, R24, R26, R29
33	70-031-100	2	RESM1/8#15K	R11, R13
34	70-031-112	1	RESM1/8#47K	R14
35	70-031-120	5	RESM1/8#100K	R3, R17, R18, R25, R28
36	70-031-128	4	RESM1/8#220K	R8, R20, R21, R31
37	70-031-144	1	RESM1/8#1M	R4
38	32-050-074	1	TRM-CRT#500K	VR3

OUTPUT R/H BOARD PARTS LIST

Item	Part Number	Qty	CAD Part Ref.	Ref. Designator
1	74-120-002	2	AMP-062V	IC1, IC3
2	74-130-001	2	AMP-064V	IC2, IC6
3	74-920-000	4	AMP-LIB	LIB1, LIB2, LIB3, LIB4
4	18-001-217	2	CAPCER22P-G	C8, C50
5	18-001-245	2	CAPCERU#4N7	C6, C61
6	18-001-213	2	CAPCERU#10P	C14, C55
7		2	CAPCERU#22P	C9, C51
8	18-015-507	4	CAPELEC1.0H1	C12, C13, C56, C57
9	18-015-411	2	CAPELEC4.7E1	C1, C48
10	18-015-213	8	CAPELEC100C1	C10, C11, C19, C20, C23, C24, C52, C53
11	18-015-217	2	CAPELEC470C1	C7, C49
12	18-001-409	2	CCU#4P7	C31, C37
13	18-001-213	2	CCU#10P	C18, C22
14	18-015-215	2	CER22-16	C32, C38
15	18-015-217	2	CER47-10	C62, C63
16	18-015-217	2	CER47L-16	C21, C25
17	USE_STANDARD_WIRE	16	CONWWIR	CONWWIR/1, CONWWIR/1, CONWWIR/2, CONWWIR/3, CONWWIR/4, CONWWIR/5, CONWWIR/6, CONWWIR/7, CONWWIR/8, CONWWIR/9, CONWWIR/10, CONWWIR/11, CONWWIR/12, CONWWIR/13, CONWWIR/14, CONWWIR/15
18	74-020-002	1	DG413	IC4
19	27-023-002	2	DIN16MRA	CON1, CON2
20	72-010-001	8	DIO-1N4148	D1, D2, D3, D4, D5, D6, D7, D8
21	72-025-005	2	FET-BF256A	TR2, TR3
22	52-055-416	2	POTA2#50K	VR1, VR3
23	82-126-003	5	PUS204	S3, S4, S5, S6, S7
24	70-031-040	2	RESM1/8#47R	R104, R105
25	70-031-048	2	RESM1/8#100R	R53, R54
26	70-031-064	4	RESM1/8#470R	R12, R14, R24, R88
27	70-031-072	4	RESM1/8#1K	R10, R30, R40, R82
28	70-031-096	13	RESM1/8#10K	R18, R20, R21, R31, R32, R41, R42, R43, R55, R61, R86, R87, R92
29	70-031-103	6	RESM1/8#20K	R17, R19, R23, R84,

		R85, R89
30	70-031-104	1 RESM1/8#22K R65
31	70-031-112	15 RESM1/8#47K R4, R8, R15, R29, R39, R56, R57, R58, R59, R62, R63, R64, R81, R94, R99
32	70-031-118	2 RESM1/8#82K R13, R83
33	70-031-120	10 RESM1/8#100K R5, R6, R22, R36, R46, R60, R66, R90, R100, R101
34	70-031-128	6 RESM1/8#220K R9, R16, R25, R91, R93, R97
35	70-031-144	4 RESM1/8#1M R7, R11, R98, R103
36	32-050-052	4 TRM-CRT#100K VR4, VR5, VR6, VR7
37	32-050-074	1 TRM-CRT#220K VR10
38	72-012-110	1 ZEN-0.4W#5V6 ZD1

CONVERTER PARTS LIST

Item	Part Number	Qty	CAD Part Ref.	Ref. Designator
1	18-001-256	9	CCU#100N	C3, C5, C9, C13, C16, C21, C22, C23, C24
2	18-001-229	1	CCU#220P	C6
3	18-013-716	3	CER100-63	C7, C8, C10
4	18-013-219	5	CER330-16	C2, C11, C12, C14, C15
5	18-013-320	5	CER470-25	C4, C17, C18, C19, C20
6		12	CONSWIR	WIRE1, WIRE2, WIRE3, WIRE4, WIRE5, WIRE6, WIRE7, WIRE8, WIRE9, WIRE10, WIRE11, WIRE12
7	USE_STANDARD_WIRE	2	CONWWIR	WIRE13, WIRE14
8	72-011-001	1	DIO-1N4001	D1
9	72-010-001	2	DIO-1N4148	D3, D4
10	72-010-004	3	DIO-UF4002	D5, D6, D7
11	74-034-007	1	IC-4007	IC1
12	22-505-203	1	IND-U0.2#220UH	L1
13	22-505-102	3	IND-U0.4#220UH	L2, L3, L4
14	40-115-001	1	LED-5MM#RED	LED1
15	36-166-500	1	MIS-FS2#	MIS-FS2-/1
16	27-025-002	1	MOL2PIN	CON2
17	27-025-003	2	MOL3PIN	CON1, CON3